

Copyright © 2014 by Big Bike Parts, Inc. No part of this instruction sheet may be reproduced without the written permission of Big Bike Parts, Inc.

PART NO. 41-165

BEVERAGE HOLDER

CAN-AM SPYDER RT AND F3 (*SE MODELS ONLY*) 2010-NEWER

3/27/2017

TOOLS NEEDED: T15 TORX DRIVER

2.5 MM ALLEN WRENCH

2 MM ALLEN WRENCH

REMOVABLE THREAD LOCK

NOTE: REMOVABLE THREAD LOCK COMPOUND SHOULD BE USED ON ALL HARDWARE. OVER TIGHTENING SCREWS CAN CAUSE DAMAGE TO THE SWITCH BLOCK. PLEASE READ THROUGH AND UNDERSTAND THESE INSTRUCTIONS BEFORE BEGINNING. ESTIMATED INSTALLATION TIME: 10 TO 15 MIN.

NOTE: DOES NOT FIT MODELS WITH A MANUAL CLUTCH LEVER.

INSTALLATION:

1. USING A T15 TORX DRIVER REMOVE THE SCREWS ON THE FRONT OF THE LEFT HANDLEBAR CONTROL AS SHOWN IN FIG. 1. THESE WILL NOT BE REUSED.
2. APPLY THREAD LOCK NEAR THE END OF THE M4 X 40MM SCREWS SUPPLIED WITH THE MOUNT. NOTE: 2 FOR 2010-11 MODELS AND 3 FOR 2012-NEWER.
3. ASSEMBLE THE M4 X 40MM SCREWS AND SPACERS AS SHOWN IN FIG. 2.
4. USING A 2.5MM ALLEN WRENCH INSTALL THE SCREWS INTO THE LEFT HANDLEBAR CONTROL AS SHOWN IN FIG. 3 AND TIGHTEN. *NOTE: OVER TIGHTENING CAN CAUSE DAMAGE TO THE INSERTS IN THE FRONT HALF OF THE SWITCH BLOCK.*
5. SLIDE BEVERAGE HOLDER INTO MOUNT AND INSTALL THE M3 SCREW AS SHOWN IN FIG. 4
6. LET THREAD LOCK CURE FOR 24 HOUR BEFORE USING CUP HOLDER.

Scan code with
your smartphone
to view video

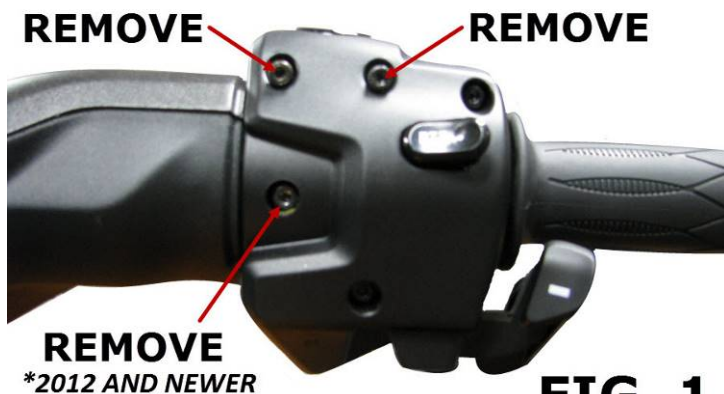
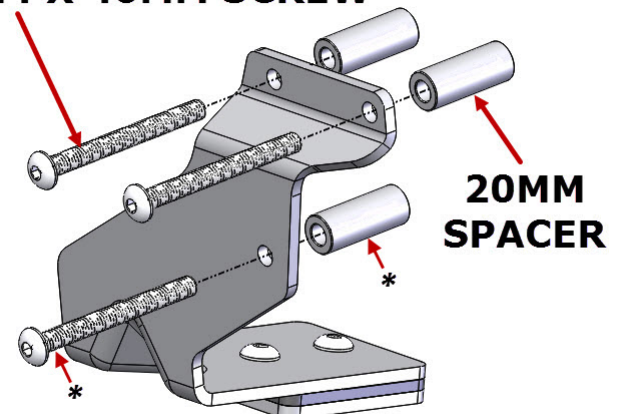
**FIG. 1****M4 X 40MM SCREW*****NOT USED FOR 2010-11****FIG. 2****FIG. 3*****2012-NEWER****FIG. 4**