

Copyright © 2015 by Big Bike Parts, Inc. No part of this instruction sheet may be reproduced without the written permission of Big Bike Parts, Inc.

PART NO. 41-171**GPS/PHONE HOLDER****CAN-AM SPYDER RT (SE MODELS ONLY) 2010-NEWER**

3/20/2015

TOOLS NEEDED:	T15 TORX DRIVER	2.5 MM ALLEN WRENCH	2 MM ALLEN WRENCH	THREAD LOCK	PHILLIPS SCREWDRIVER
	3MM ALLEN WRENCH	4MM ALLEN WRENCH	8MM WRENCH		

PLEASE READ THROUGH AND UNDERSTAND THESE INSTRUCTIONS BEFORE BEGINNING.

NOTE: USE THREAD LOCK ON ALL FASTENERS.

NOTE: DOES NOT FIT MODELS WITH A MANUAL CLUTCH LEVER.

INSTALLATION:

1. USING A T15 TORX DRIVER REMOVE THE THREE SCREWS ON THE FRONT OF THE LEFT HANDLEBAR CONTROL. SEE FIG. 1. THESE WILL NOT BE REUSED.
2. APPLY THREAD LOCK NEAR THE END OF THE THREE M4 X 40MM SCREWS SUPPLIED WITH THE MOUNT.
3. ASSEMBLE THE M4 X 40MM SCREWS AND SPACERS AS SHOWN IN FIG. 2.
4. USING A 2.5MM ALLEN WRENCH INSTALL THE THREE SCREWS INTO THE LEFT HANDLEBAR CONTROL AS SHOWN IN FIG. 3 AND TIGHTEN.
5. GPS/PHONE HOLDER CAN BE ROTATED 90 DEGREES AND MADE WIDER. SEE FIG. 4.
6. INSTALL THE SAFETY STRAP BY REMOVING THE TOP PHILLIPS SCREW ON THE BACK AND REINSTALLING IT THROUGH THE HOLE ON THE STRAP. SEE FIG. 5.
7. SLIDE THE GPS/PHONE HOLDER INTO THE MOUNT AS SHOWN IN FIG. 6. INSTALL THE M3 SCREW FOR SECURITY.
8. TIGHTEN THE SCREWS AND ADJUST THE MOUNT TO THE DESIRED POSITION.
9. TURN THE LOCKING KNOB COUNTER CLOCKWISE UNTIL YOU SEE THE SET SCREW ON THE KNOB AND OPEN THE CLAMP. SEE FIG. 7.
10. SQUEEZE THE CLAMP TOGETHER AND ROTATE THE KNOB CLOCKWISE UNTIL THE ARROWS LINE UP. SEE FIG. 8.
11. TIGHTLY WRAP SAFETY STRAP AROUND THE DEVICE BEFORE USE.

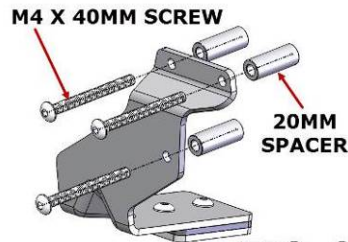
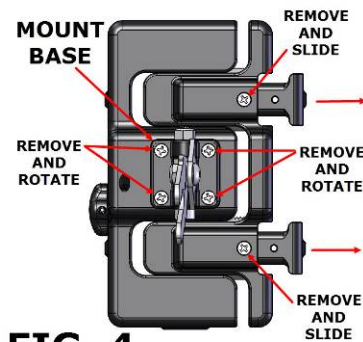
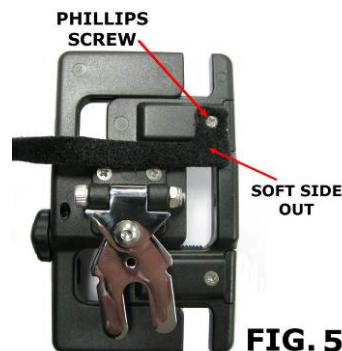
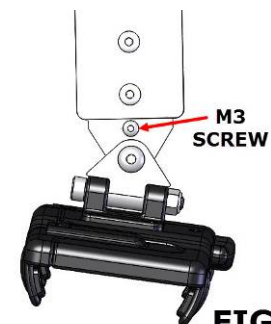
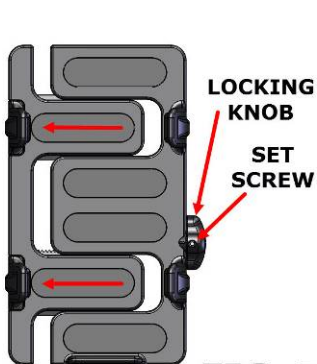
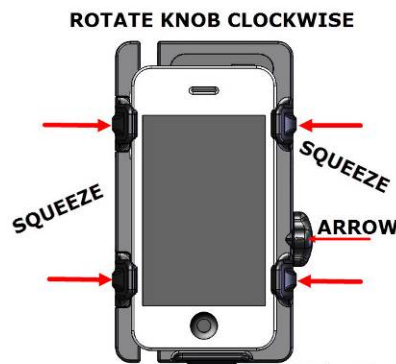
**FIG. 1****FIG. 2****FIG. 3****FIG. 4****FIG. 5****FIG. 6****FIG. 7****FIG. 8**

Scan code with your smartphone to view video

