

Copyright © 2015 by Big Bike Parts, Inc. No part of this instruction sheet may be reproduced without the written permission of Big Bike Parts, Inc.

PART NO. 41-175**PASSENGER FLOORBOARD KIT****CAN-AM SPYDER RT 2010-NEWER**

2/18/2016

TOOLS NEEDED:	13MM WRENCH (2X)	5MM ALLEN WRENCH	8MM ALLEN WRENCH	THREAD LOCK
HARDWARE INCLUDED:	RIGHT SIDE BEACHCOMBER BOARD (1X) LEFT SIDE BEACHCOMBER BOARD (1X) M8-1.25 X 80MM LG. BUTTON SOCKET HEAD BOLT	BOARD MOUNT (2X) M10-1.5 X 40MM SOCKET HEAD BOLT (2X)		

NOTE: THREAD LOCK COMPOUND SHOULD BE USED ON ALL HARDWARE.
PLEASE READ THROUGH AND UNDERSTAND THESE INSTRUCTIONS BEFORE BEGINNING.
ESTIMATED INSTALLATION TIME: 15 TO 20 MIN.

INSTALLATION:

1. STARTING ON THE LEFT SIDE, USING TWO 13MM WRENCHES REMOVE THE TWO M8-1.25 OEM NUTS THAT ARE ON THE END OF THE BOLT HOLDING THE OEM PASSENGER FOOTREST TO THE SPYDER. THESE WILL NOT BE REUSED. (2010-2013 ONLY)
2. USING A 5MM ALLEN WRENCH (2010 – 2013) OR A 13MM WRENCH (2014 – NEWER) REMOVE THE M8-1.25 X 90MM OEM BOLT AND FLAT WASHER. REMOVE THE OEM FOOT REST AND THE OEM CLAMPING BLOCK. THE WASHER AND CLAMPING BLOCK WILL BE REUSED.
3. TAKE ONE OF THE NEW BOARD MOUNTS AND INSERT THE M8-1.25 X 80MM BOLT (SUPPLIED) AND THE (OEM) FLAT WASHER THROUGH THE HOLE AS SHOWN IN FIG. 1 BELOW.
4. INSERT THE KNOB ON THE BACK OF THE BOARD MOUNT INTO THE SLOT ON THE SPYDER AND INSTALL THE CLAMPING NUT ON THE INSIDE AND TIGHTEN. MAKE SURE THE GROOVES IN THE CLAMPING NUT LINE UP WITH THE TEETH ON THE SPYDER.
5. ATTACH THE LEFT SIDE BOARD TO THE BOARD MOUNT USING THE M10-1.5 X 40MM LONG ALLEN BOLT. TIGHTEN WITH AN 8MM ALLEN WRENCH.
6. REPEAT STEPS 1 THROUGH 5 ON THE RIGHT SIDE OF THE SPYDER.
7. USING A 5MM ALLEN WRENCH ADJUST THE HEIGHT OF BOTH SIDES TO THE DESIRED POSITION AND TIGHTEN.

NOTE: THE BOARD MOUNT CAN BE ROTATED 180 DEGREES TO ALLOW A LOWER BOARD POSITION.

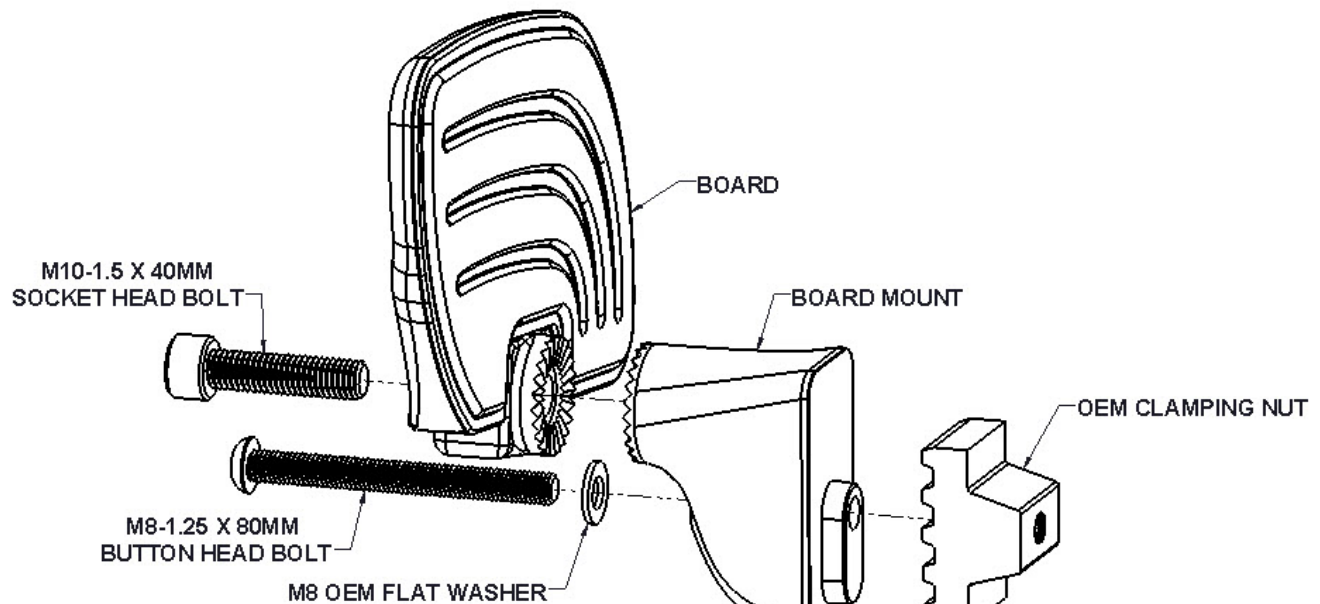
**FIG. 1**

Scan code with
your smartphone
to view video

