

Copyright® 2020 by Big Bike Parts, Inc. No part of this instruction sheet may be reproduced without the written permission of Big Bike Parts, Inc.

PART NO. 41-264

TRAILER HITCH

CAN-AM SPYDER RT/F3T/F3LTD 2020-NEWER

5/29/2020

TOOLS NEEDED:	PLIERS	13MM WRENCH	4MM ALLEN WRENCH	17MM WRENCH (2X)	REMOVABLE THREAD LOCK
INCLUDED IN HITCH KIT:	HITCH FRAME	RIGHT MOUNT	LEFT MOUNT	M10 X 462MM BOLT	5/8" X 3/4" SPACER (2X)
	AXLE CAP	M8X12MM SET SCREW(2X)	M10 HEX NUT	M10 LOCK WASHER (8X)	M10 X 20MM BOLT (6X)
MUD FLAP KIT:	FLAT BRACKETS (2X)	M6 WASHER (2X)	M6 X 20MM BOLT (2X)	M6 X 30MM BOLT (2X)	M6 LOCK NUT (4X)

PLEASE READ THROUGH AND UNDERSTAND THESE INSTRUCTIONS BEFORE BEGINNING.

ESTIMATED INSTALLATION TIME: 25 TO 40 MIN. **REMOVABLE THREAD LOCK SHOULD BE USED ON ALL FASTENERS**

INSTALLATION:

1. REMOVE THE 2 BLACK PLASTIC CAPS COVERING THE AXLE ON THE BACK OF THE SPYDER. PULL OUT TO REMOVE.
2. USE A PAIR OF PLIERS TO REMOVE THE COTTER PIN FROM THE END OF THE AXLE ON THE RIGHT SIDE. THE COTTER PIN IS NOT REUSED BUT YOU SHOULD SAVE IT TO USE IF YOU EVER COMPLETELY REMOVE THE TRAILER HITCH FROM THE SPYDER.
3. TAKE THE TWO 5/8" X 3/4" SPACERS AND SLIDE ONE INTO EACH SIDE OF THE AXLE. IF THEY ARE LOOSE PUT A PIECE OF MASKING TAPE ON THE OUTSIDE OF THE SPACER SO THEY FIT TIGHT. PUSH THEM IN SO THEY ARE FLUSH WITH THE END OF THE AXLE (FIG. 1).
4. TAKE AN M8 X 12MM LONG SET SCREW AND THREAD IT INTO THE WELD NUT ON THE BOTTOM OF THE RIGHT MOUNT (FIG. 2). JUST GET IT STARTED. DO NOT THREAD IT IN ALL THE WAY. REPEAT ON LEFT MOUNT.
5. STARTING ON THE RIGHT SIDE, SLIDE THE RIGHT MOUNT OVER THE END OF THE RIGHT SWING ARM (FIG. 3). HOLD THE MOUNT TIGHT AGAINST THE SWING ARM AND TIGHTEN THE SET SCREW USING A 4MM ALLEN WRENCH.
6. REPEAT STEP 5 ON THE LEFT SIDE.
7. TAKE THE AXLE CAP FROM THE KIT AND PLACE IT OVER THE END OF THE AXLE ON THE RIGHT SIDE (FIG. 4).
8. INSTALL THE M10 X 462MM LONG BOLT WITH A LOCK WASHER FROM THE LEFT SIDE. PUSH IT THROUGH THE SPACERS IN THE AXLE FROM STEP 4 AND OUT THE RIGHT SIDE (FIG. 5).
9. INSTALL THE M10 HEX NUT AND A LOCK WASHER ON THE RIGHT SIDE AS SHOWN IN FIG. 5. USING TWO 17MM WRENCHES TIGHT THE BOLT AND NUT.
10. INSERT THE HITCH FRAME INTO THE MOUNTS WITH BALL MOUNT HOLE ON THE TOP. INSTALL THE SIX M10 X 20MM LONG HEX BOLTS WITH LOCK WASHER AND TIGHTEN (FIG. 6).
11. **ALWAYS CHECK ALL OF THE BOLTS TO MAKE SURE THEY ARE TIGHT BEFORE USING.**
12. A MUD FLAP MOUNTING KIT IS INCLUDED WITH THE TRAILER HITCH. USE BIG BIKE PARTS PART NUMBER 2-111 MUD FLAP (NOT INCLUDED). SEE FIG. 7 AND FIG. 8 FOR THE TWO POSITIONS TO MOUNT THE MUD FLAP.

NOTICE

IGNORING THE CONTENTS OF THESE INSTRUCTIONS MAY AFFECT THE PRODUCT PERFORMANCE AND FUNCTIONALITY. NOT FOLLOWING THESE INSTRUCTION MAY CAUSE DAMAGE TO THE PRODUCT OR THE VEHICLE TO WHICH IT IS BEING ATTACHED.

NOTICE

Big Bike Parts and it's Show Chrome Accessories® trailer hitch systems have been exclusively designed for use only on stock models. It will not work on any other motorcycle, and may not work or may interfere with aftermarket accessories. Any modification to any part of this hitch, including but not limited to altering the supplied hardware or improper installation could cause injury or death and immediately voids any and all warranties. Use of a trailer hitch on any motorcycle could void your motorcycle warranty and may increase your chances of injury or death. The end user of this product assumes all liability and responsibilities that may arise due to but not limited to, negligence from improper installation or use, including overloading, exceeding the recommended load limits of the motorcycle, trailer or trailer hitch and improper maintenance. Big Bike Parts total liability will be limited to the initial purchase price of this product or replacement of this product or replacement of this product at our discretion. 600 lbs. maximum GVWR, 60 lbs. maximum tongue weight, not to exceed GCWR for motorcycle.

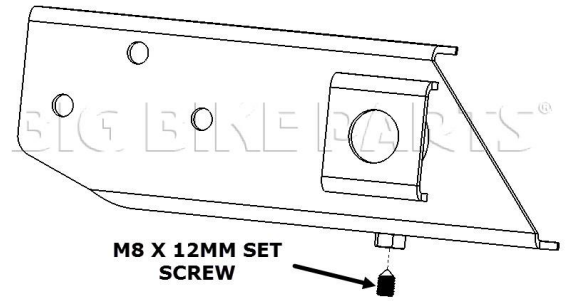
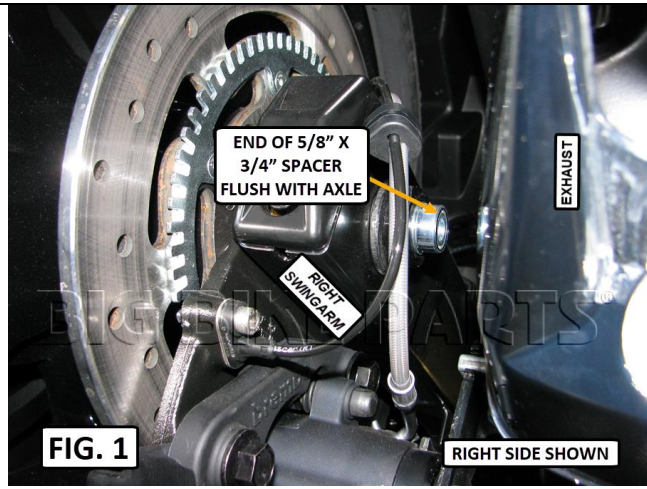

FIG. 2

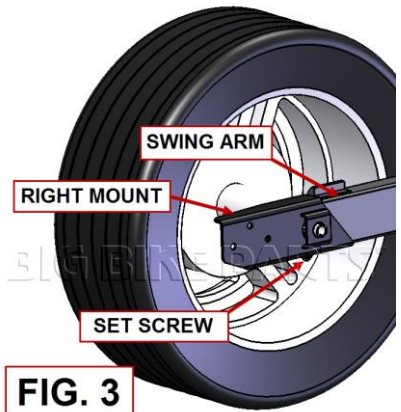

FIG. 3

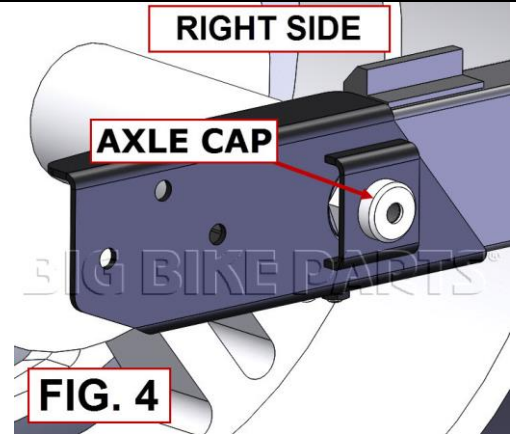

FIG. 4



FIG. 5

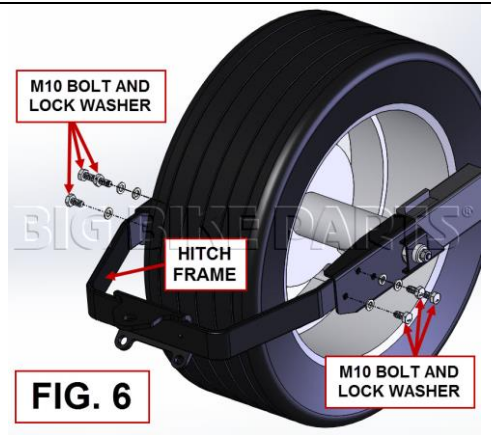

FIG. 6

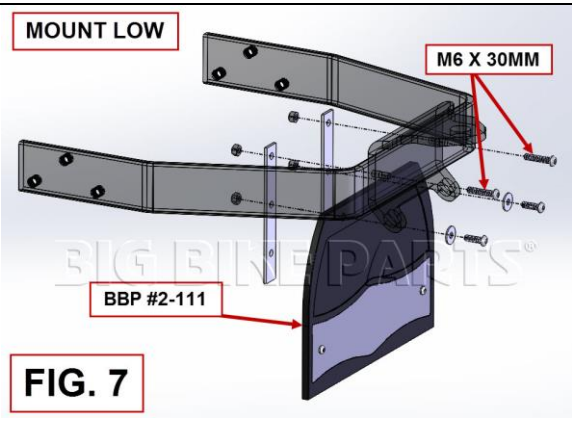

FIG. 7

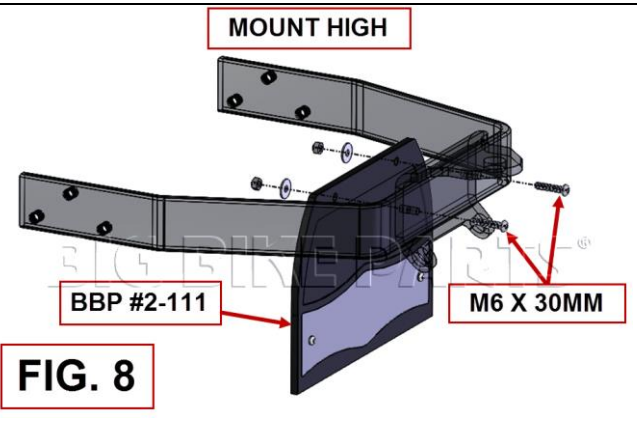

FIG. 8